

LOC	DIST	REVISIONS				
DF	DO	REV	DESCRIPTION	DATE	DRN	APVD
		M	REV PER ECO 05-014956	24JAN06	BL	CT
		N	REV PER ECO-08-018752	21AUG08	PK	BW

- THIS PLUG WILL MATE WITH ANY 21C4, SIZE 4 RECEPTACLE IN AMPLIMITE SERIES.
- MAXIMUM WIRE INSULATION TO BE USED WITH THIS PLUG IS $\phi.072$.
- RETENTION CLIPS (17) ARE INCLUDED IN INSERT ASSEMBLY.
- THIS CONNECTOR ACCEPTS SIZE 20 PIN CONTACTS, NOT PROVIDED, IN CAVITIES 1 THRU 17.
- CAVITIES A1 THRU A4 ACCEPTS SIZE 8 POWER OR COAX PIN CONTACTS, NOT PROVIDED. RIGHT ANGLE COAX CONTACTS WILL NOT SEAT IN THIS CONNECTOR.

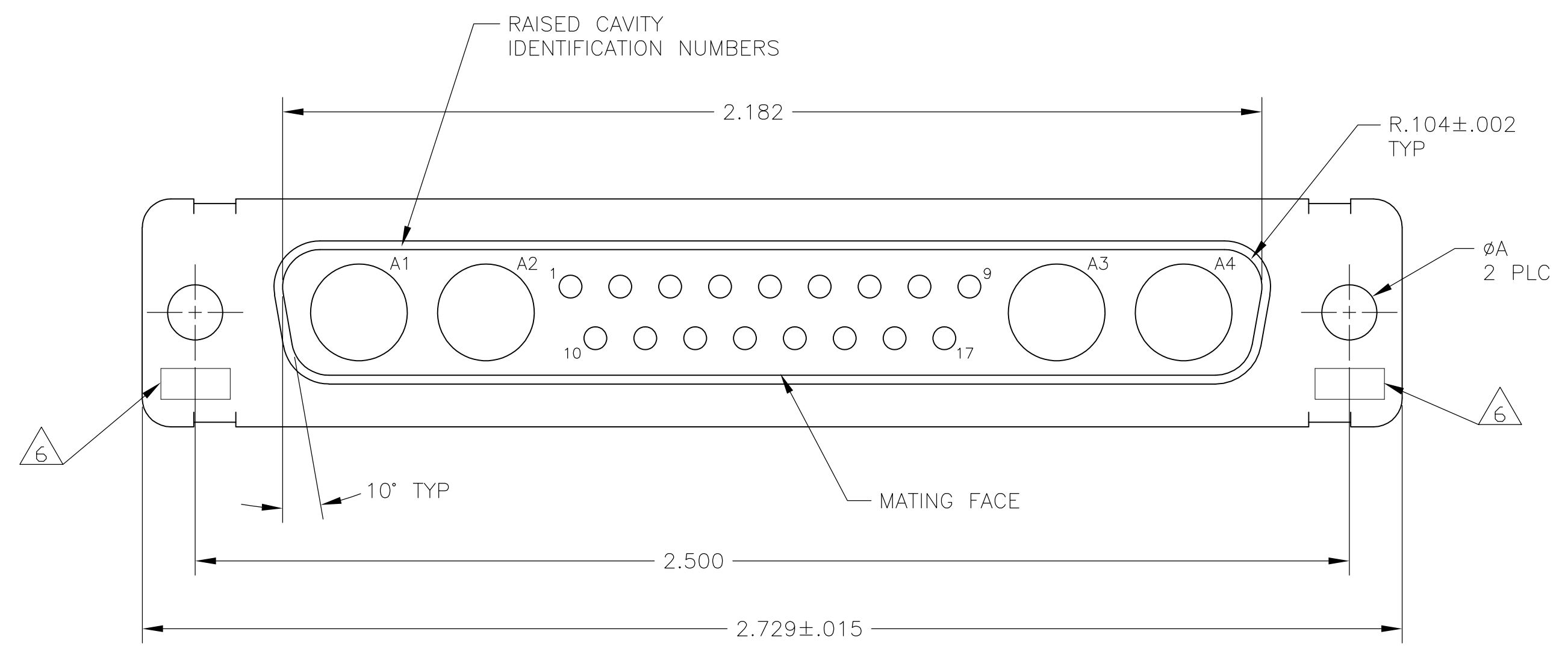

- 6 UL/CSA DESIGNATION STAMPED IN THIS AREA, OPTIONAL.
- 7 MATERIAL: STEEL PER ASTM-A-109.
- 8 FINISH: CADMIUM PLATED PER QQ-P-416, TYPE II, CLASS 2.
- 9 MATERIAL: BRASS PER ASTM-B-36.
- 10 FINISH: GOLD PER MIL-G-45204, TYPE II, GRADE C, CLASS 1 OVER COPPER PER MIL-C-14550, CLASS IV.
- 11 FINISH: TIN PER ASTM-B-545 .000200 MIN THK OVER COPPER PER AMS2418 .000100-.000200 THK OR TIN-LEAD 93/7 .000200 MIN THK OVER COPPER PER AMS2418 .000100-.000200 THK.
- 12 GROUNDING INDENTS FOR 212530-4, 212530-5, & 5-212530-4 ONLY.
- 13 212530-6 IS OBSOLETE.
- 14 FINISH: BRIGHT TIN PER ASTM-B-545 .000400-.000550 THK OVER COPPER PER AMS2418 .000050 MIN THK.
- 15 FINISH: TIN PER ASTM-B-545 .000200 MIN THK OVER COPPER PER AMS2418 .000100-.000200 THK.
- 16 FINISH: ZINC PLATE PER ASTM-B-633 .000200-.000400 THK WITH SUPPLEMENTARY CHROMATE (Cr3+).

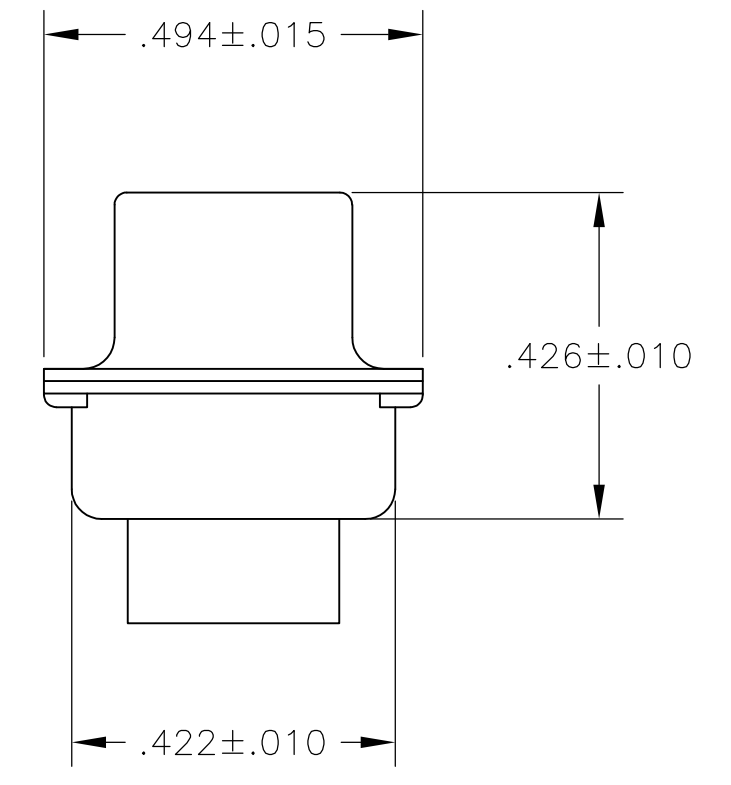
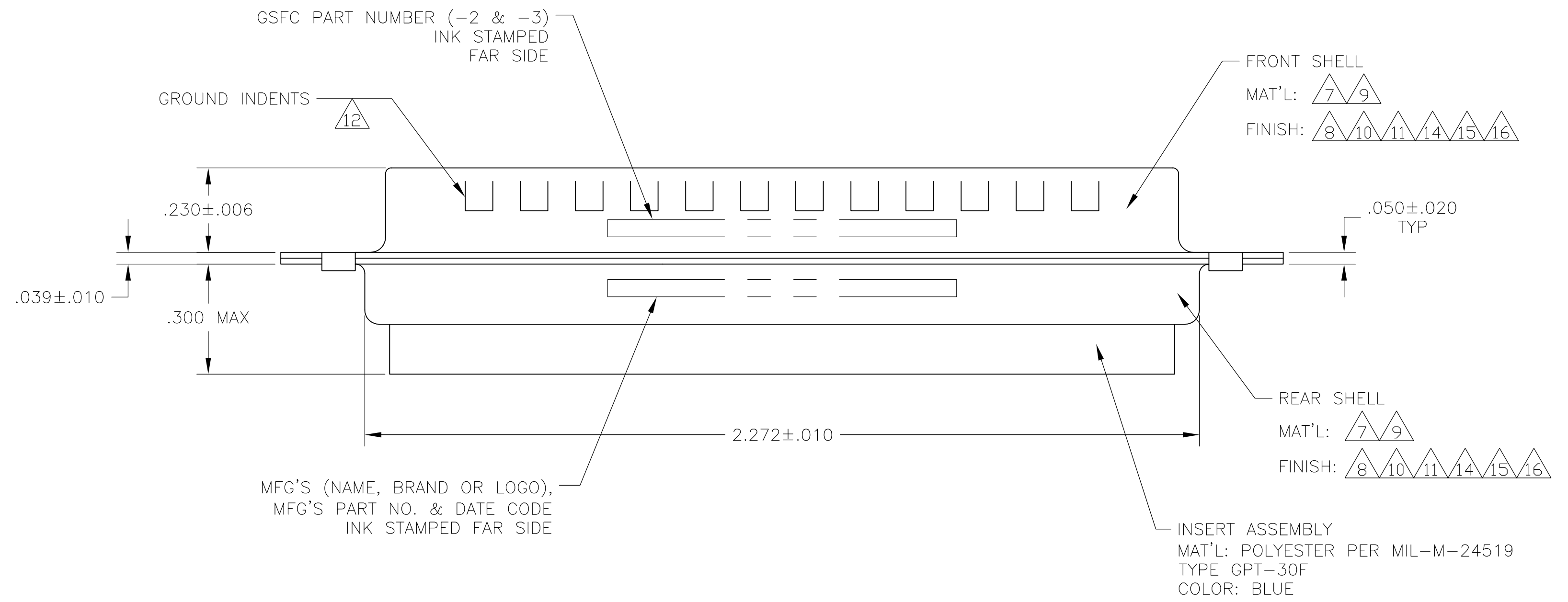

7, 12, 15	.120	-	5-212530-4
7, 16	.120	-	5-212530-1
7, 14	.120	-	212530-6
7, 12, 14	.120	-	212530-5
7, 11, 12	.120	-	212530-4
9, 10	.154	311P405-18P-B-15	212530-3
9, 10	.120	311P405-18P-B-12	212530-2
7, 8	.120	-	212530-1
REMARKS	ϕA	GSFC P/N	PART NO.

THIS DRAWING IS A CONTROLLED DOCUMENT.

DW	C.C. THOMAS	21-JAN-89	Tyco Electronics Corporation Harrisburg, Pa 17105-3608
CHK	A. EMADI	27-JAN-88	
APP'D	A. EMADI	27-JAN-88	Tyco Electronics Corporation Harrisburg, Pa 17105-3608
NAME	A. EMADI	27-JAN-88	
PRODUCT SPEC	PLUG ASSEMBLY AMPLIMITE 21C4 SIZE 4, SERIES 109, COAX MIX		
APPLICATION SPEC	SIZE: CAGE CODE: DRAWING NO: RESTRICTED TO		
MATERIAL	FINISH	WEIGHT	A1 00779 ©=212530
CUSTOMER DRAWING		SCALE	4:1 SHEET 1 OF 1 REV N